

Project: _____	AIA# _____
Item #: _____ Qty: _____	SIS# _____
Model #: _____	

Dry Waste Rail

DWR-12

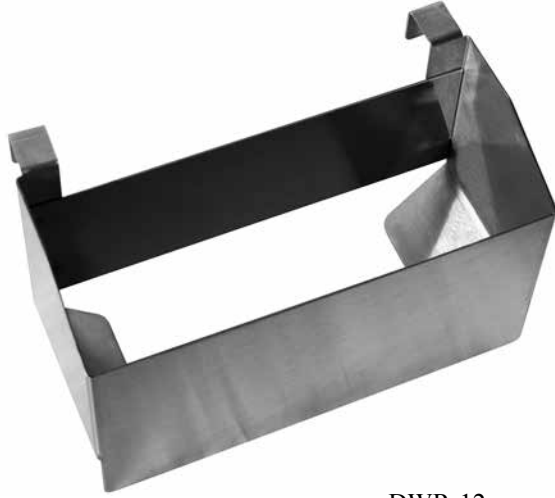

DWR-12
(clip on style shown)

Standard Features

- All stainless steel construction
- Matches speed rail profile for continuity of design
- Two rail styles available:
 1. Clip on - clips to the rail of an underbar speedrail
 2. Key hole - bolts to the front skirt of non-cabinet base underbar equipment (this option is configured within the model number when ordering)
- Stainless steel chute is removable for cleaning



Cleaning & care instructions: <https://www.glastender.com/support/documents/manuals/general-cleaning-and-care-instructions-for-stainless-steel>

Specifications

Materials

- 16 gauge stainless steel

The removable stainless steel Dry Waste Rail is a 12" wide by 5" deep trash chute that matches the profile of a speed rail. A 16" high or shorter trash receptacle is placed under the dry waste rail and the chute directs the refuse into the receptacle. Dry waste rails cannot be used on cabinet base underbar equipment. A stainless steel dry waste receptacle, model DWC, is available as an accessory.

Glastender, Inc. • 5400 N Michigan Rd • Saginaw, MI • 48604-9780 989.752.4275 • 800.748.0423 • Fax 989.752.4444 www.glastender.com	Approval/Notes:
<small>Specifications subject to change without notice. For current specifications please visit our website.</small>	

Dry Waste Rail

Dimensional Information

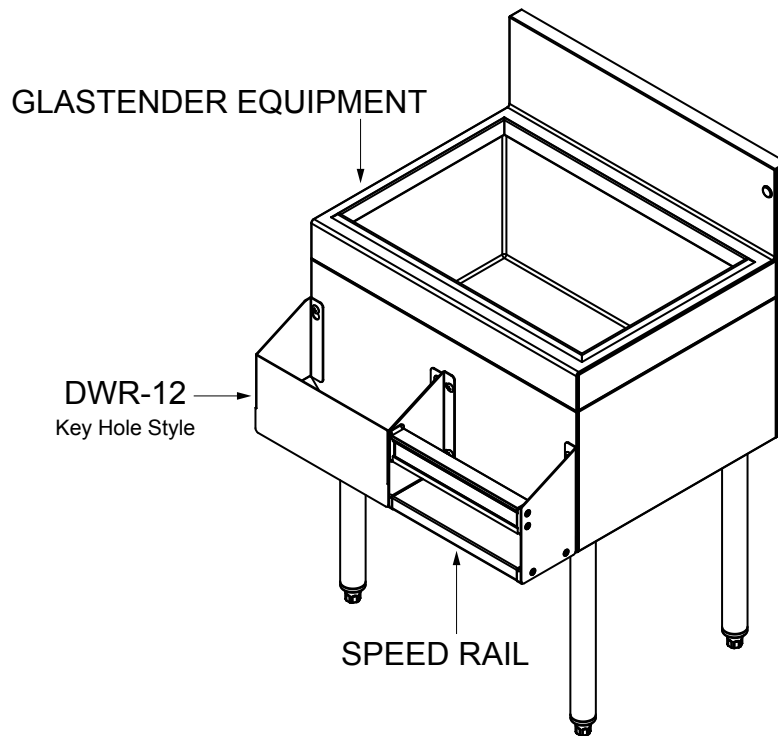

DWR-12 - CLIP ON STYLE

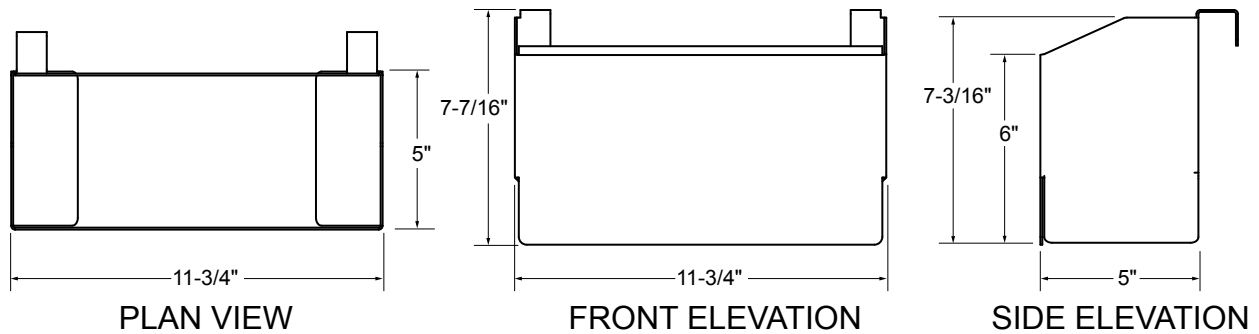

DWR-12 - KEY HOLE STYLE

