

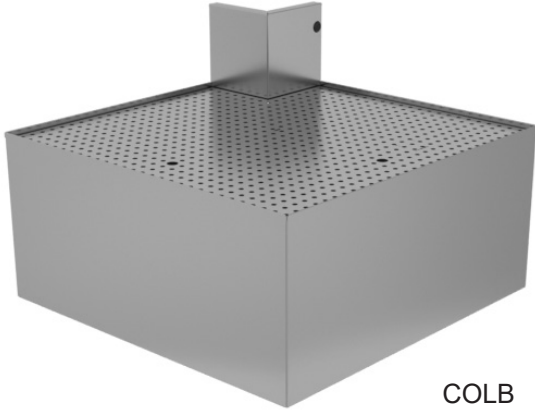

A family company manufacturing in the USA

www.glastender.com



COLB



Intertek

4004503

Conforms to ANSI/NSF STD 2

Project: _____	AIA# _____
Item #: _____ Qty: _____	SIS# _____
Model #: _____	

Corner Outside L Shape Drainboards

COLB	COLB, COLB-LN
------	---------------

Standard Features

- All stainless steel
- Designed to mount between two adjacent pieces of Glastender underbar equipment (unless optional legs are used, see configurable options)
- Drain pan with separate perforated insert for better air circulation
- 1/4" radius work surface corners for easy cleaning

Configurable Options

- Leg set for one side mounting
- Leg set for freestanding

Specifications

Drain

- 1/2" welded tailpiece drain

Materials

- 20 gauge stainless steel

To view underbar installation instructions: <https://www.glastender.com/support/documents/manuals/underbar-installation-instructions>

Cleaning & care instructions: <https://www.glastender.com/support/documents/manuals/general-cleaning-and-care-instructions-for-stainless-steel>

Drawing Information

PLAN VIEWS

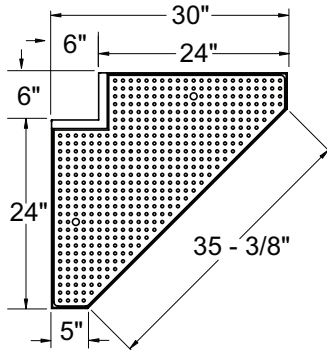

COLB-LN

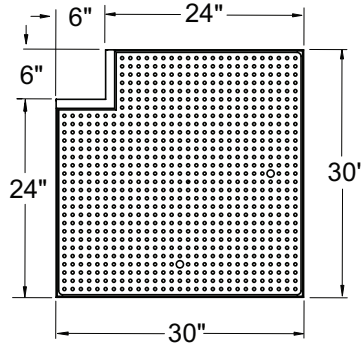

COLB

Glastender, Inc. • 5400 N Michigan Rd • Saginaw, MI • 48604-9780
 989.752.4275 • 800.748.0423 • Fax 989.752.4444
 www.glastender.com

Approval/Notes:

Specifications subject to change without notice. For current specifications please visit our website.