

Project: _____	AIA# _____
Item #: _____ Qty: _____	SIS# _____
Model #: _____	

Corner Inside Wedge Fillerboards



C-CIWB-15



Intertek
4004503
Conforms to ANSI/NSF STD 2

C-CIW

C-CIWB-5, C-CIWB-10, C-CIWB-15,
C-CIWB-20, C-CIWB-25, C-CIWB-30,
C-CIWB-45

Standard Features

- All stainless steel
- Designed to mount between two adjacent pieces of Choice underbar equipment
- Flat work surface excluding 45° model which features a corrugated work surface

Specifications

Materials

- 20 gauge stainless steel

Drain

- 1-1/2" I.P.S. Threaded drain will fit Dearborn part #8033 slipnut and part #W-573P washer (*C-CIWB-45 model only*)

Configurable Options

- Leg set for one-side mounting (*model C-CIWB-45 only*)

Choice installation instructions: <https://www.glastender.com/support/documents/manuals/choice-line-mounting-instructions>

Cleaning & care instructions: <https://www.glastender.com/support/documents/manuals/general-cleaning-and-care-instructions-for-stainless-steel>

Dimensional Information

PLAN VIEWS

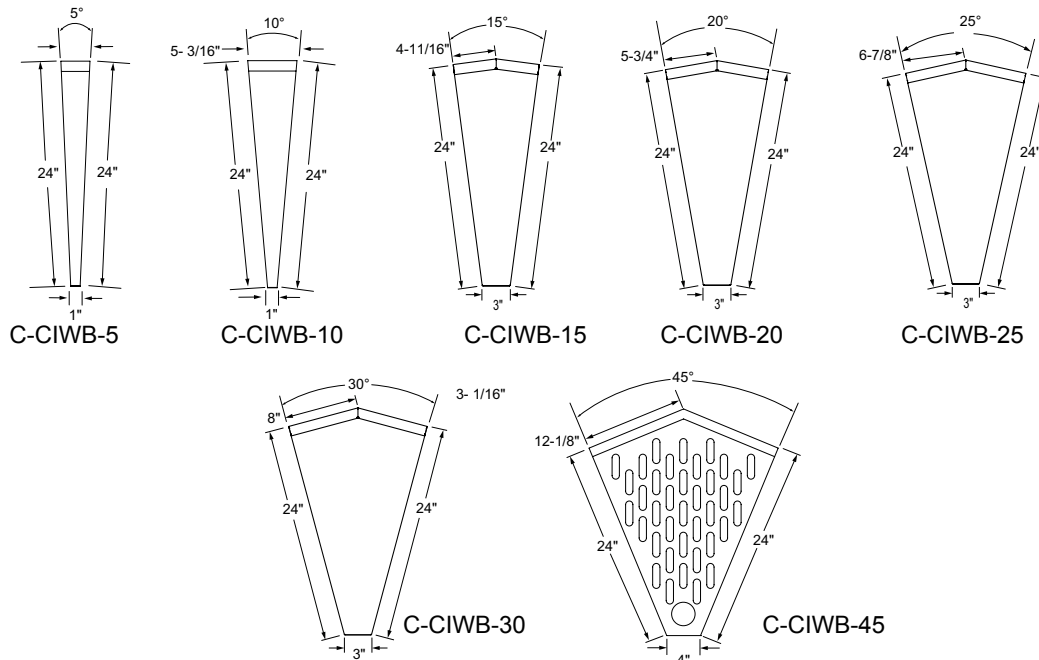

Glastender, Inc. • 5400 North Michigan Road • Saginaw, MI • 48604-9780
989.752.4275 • 800.748.0423 • Fax 989.752.4444
<https://glastender.com>

Approval/Notes:

Specifications subject to change without notice. For current specifications please visit our website.