

Operation Manual

Glastender®

GW24 GLASSWASHER

A Family Company Manufacturing
In The USA Since 1969

GW24 Glasswasher Operation & Maintenance Video -

https://youtu.be/4pFZOWI6I_A?si=HmbilSv64gcxUsXe

This video describes the operation of the Glastender GW24 glasswasher. Please follow all steps carefully. Long term, trouble-free operation will result if good housekeeping and maintenance procedures are followed.



Glastender, Inc. · 5400 North Michigan Road · Saginaw, MI · 48604-9780
800.748.0423 · 989.752.4275 · Fax 989.752.4444 · <https://glastender.com>



INDEX

<u>Topic</u>	<u>Page</u>
Introduction.....	1
What is a glasswasher?	1
Utility Requirements and Connections	2
Uncrating and Assembly Instructions	2
GW24 Parts Identification.....	3
Start-Up Instructions.....	4-5
Water Level/Temperature Adjustment Procedure	4
Chemical Adjustment Procedure.....	5
Control Panel Operation.....	6
Wash Cycle Description	6
Wiring Diagram.....	7
Cleaning Instructions.....	8-9
De-liming Procedure.....	9
Slide-Out Chemical Bottle Rack Installation.....	10
Useful Information About Water, Detergent and Sanitizer	11
Important Information about Chemicals	12
Tips for Trouble-Free Operation.....	12
Trouble Shooting Guide	13

Terms and Conditions

<https://www.glastender.com/support/documents/policies/terms-and-conditions>

Warranty

IMPORTANT !! Attention Service Companies IMPORTANT !!

Please review the important warranty information found here:

<https://www.glastender.com/support/documents/warranty/warranty-statement-form>

If you believe a service call should be covered by the factory, please call 800-748-0423
for authorization 8AM - 5PM EST, Monday through Friday.

For replacement part information, visit:
<https://www.glastender.com/support/parts>

Glastender®

Glastender, Inc. • 5400 North Michigan Road • Saginaw, MI • 48604-9780
800.748.0423 • 989.752.4275 • Fax 989.752.4444 • www.glastender.com

GW24

Introduction

This manual describes the operational features of the GW24 model glasswasher. Please review this information before attempting installation and operation. Long term, trouble-free operation will follow if good housekeeping and maintenance procedures are followed.

For a video illustration of care and cleaning of the GW24 visit <https://glastender.com/pl/products/gw24/operation-manual>

Thank you for selecting Glastender, Inc. products.

What is a Glasswasher?

Glastender, Inc. invented the world's first automatic rotary glasswasher in 1969. Today, Glastender glasswashers have been installed around the world. But what is a glasswasher? It is simply a piece of machinery that washes glassware, which eliminates the need for human labor and the conventional three-compartment sink. The glasswasher is, in effect, a mechanized three-compartment sink. It "washes", "rinses", and "sanitizes" glassware.

Note the Simplicity:

FUNCTION

DESIGN

WASH

Hot water and a preset portion of detergent join in the tank. During operation, hot soapy water is pumped in a forceful, but gentle, spray pattern across the moving glassware. When the wash cycle is complete, all water is drained. While the drain is still open, clean water pre-rinses the holding tank to prepare for the rinse and sanitize cycle.

RINSE AND SANITIZE

Fresh water and a preset portion of sanitizer and rinse aid join in the tank. During operation, rinse water is pumped in a forceful, but gentle, spray pattern across the moving glassware. At the end of the cycle, all water is drained so the next load can begin with fresh, clean water.

Please read on to learn more about this simple machine.

Utility Requirements and Connections

- 1. GENERAL PLUMBING**
(Hot and cold water required)
 - a. Use 1/2" OD (or larger) copper to 3/8" FMPT adapter provided.
 - b. Minimum water pressure - 25 PSI.
 - c. Maximum water pressure - 100 PSI. Install water pressure regulator if line pressure is over 100 PSI. Water valve on unit has built-in strainer and flow control to provide consistent volume between 25 and 100 PSI.
 - d. Install separate water shut-off valve for each connection.
 - e. Unit has built-in air gaps - vacuum breakers NOT required.
- 2. HOT WATER WASH**
 - a. Maximum temperature 150°F (66°C). Minimum supply temperature 130°F (54°C) to ensure a minimum wash temperature of 120°F (49°C).
- 3. COLD WATER RINSE**
 - a. No minimum cold water inlet temperature. Control module automatically tempers rinse based on temperature setting (see Start-Up Instructions page 5, Step 5).
- 2. DRAIN**
 - a. 1-1/2" tailpiece provided on unit.
 - b. Use open type floor drain for maximum drainage.
- 3. ELECTRICAL**
 - a. 120V, single phase, 60Hz, 6-foot grounded cord included.
 - b. A dedicated 15 amp circuit is recommended.
 - c. Power requirements - 3.5 amps.
- 4. DETERGENT**
 - a. Extra heavy-duty non-foaming commercial liquid dish detergent required. Adjust to .30% concentration.
 - b. Consult The local chemical supplier to match detergent with local water conditions.
- 5. SANITIZER**
 - a. Liquid chlorine bleach (sodium hypochlorite - 5.25% solution) adjusted to 50 PPM.
- 6. RINSE AID**
 - a. Liquid Rinse Aid adjusted for proper sheeting.
- 7. NOTES**
 - a. In all cases, consult local plumbing, electrical, and health codes for regulations which may not be consistent with the above.
 - b. Utility connections are made up from the floor at the bottom of the unit approximately 6" high.
 - c. A side notch located on the left side of the unit provides space for three one-gallon chemical containers within the 24" x 24" footprint.

Uncrating and Assembly Instructions

The glasswasher is shipped in one carton. Refer to the images on the opposite page to identify the following:

- | | | |
|----------------------|---------------------|---------------------|
| 1. Main section | 6. Conveyor | 11. Inlet screen |
| 2. Drainboard insert | 7. Spray box | 12. Scrap tray |
| 3. Drainboard pan | 8. Spray box gasket | 13. Water inlets |
| 4. Sliding cover | 9. Tank screen | 14. Chemical inlets |
| 5. Inner cover | 10. Drain stopper | |

Assembly Procedures:

1. Remove all packaging from the main section.
2. Remove plastic protective paper from all stainless steel parts.
3. Place glasswasher in position and level by adjusting the bottom portion of the stainless legs.
4. Make plumbing connections in accordance with utility requirements listed above.
5. Install chemical bottle rack accessory if ordered with unit. See page 10 for installation instructions.

GW24 Part Identification*

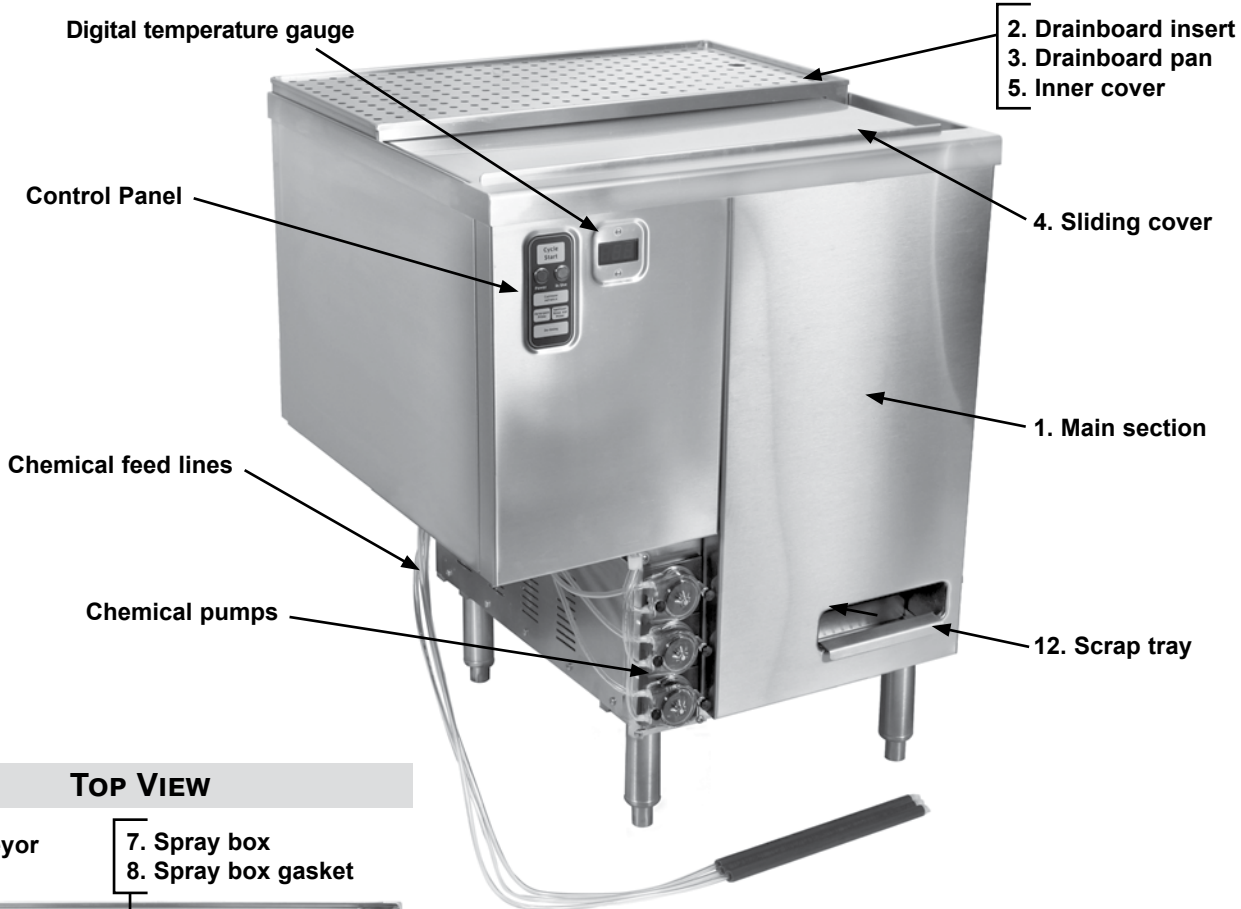

TOP VIEW

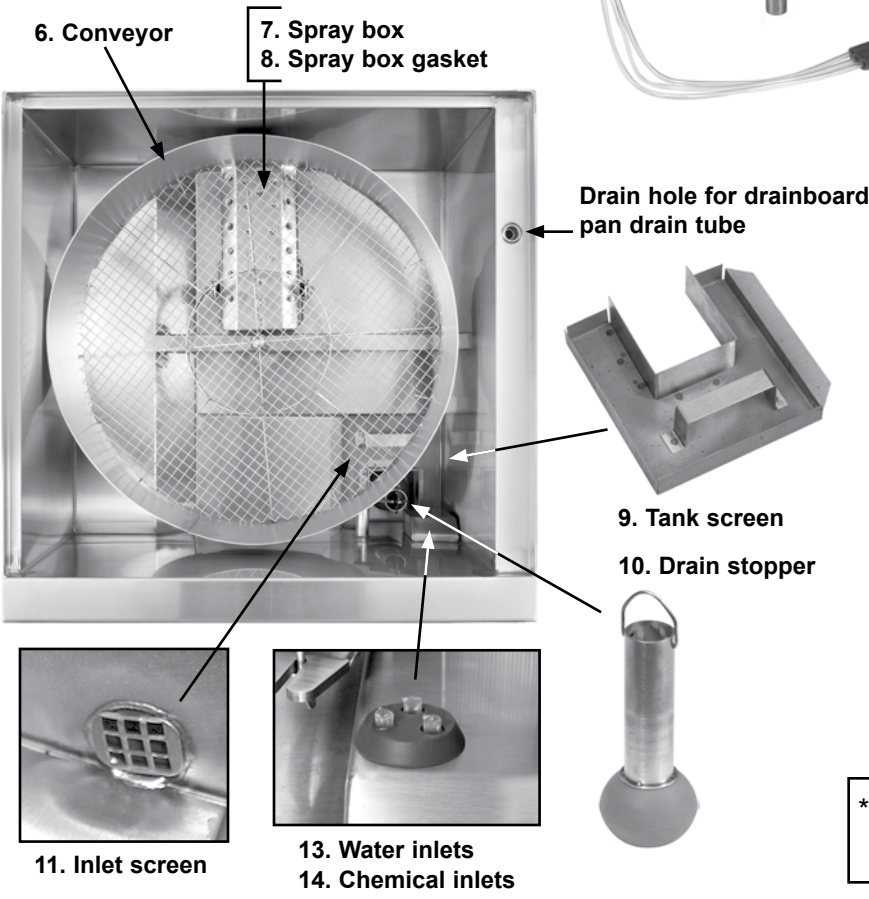

FRONT PANEL REMOVED

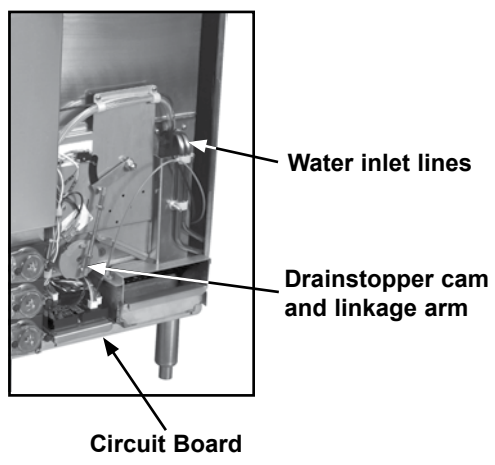

* For a more comprehensive parts list, visit <https://glastender.com/support/parts>

Start-Up Instructions

WARNING: The chemicals used in commercial glass washing are very harsh. Exposure to human skin can cause severe burns. Chemical containers should be stored in a manner and/or location that prevents them from spilling or splashing. Chemical containers must be secured. Please consult your chemical vendor to ensure proper storage or call the Glastender factory to purchase an accessory chemical storage drawer, part number 01001500.

1. Place chemical Feed Lines into the proper chemical containers.

Red - Detergent

Blue - Rinse Aid

Clear - Sanitizer

2. After utility connections described on page 2 are completed, plug in glass-washer.

3. **Prime Chemical Pumps:** Slide cover open to view chemical inlets.

Depress Prime switches to fill Feed Lines (see page 6 - Control Panel Operation).

Stop priming when chemicals come out of inlets.

NOTE: Always run a complete cycle or dump clean water in the tank after using the prime switches. Undiluted chemicals will damage stainless steel.

4. **Fill Level Adjustment:** Cycle the glasswasher to check water fill level (water fill level is preset at the factory but may require adjustments due to variations in water pressure/flow at installation location).

With the sliding cover open, initiate cycle by pressing Cycle Start (see page 6 - Control Panel Operation).

When fill is complete, verify that the water level is at the FILL mark (top of the drain screen handle - see photo below).

If water level is correct, skip to Step 5.

If water level is above or below the fill mark, fill adjustment is required.

- Unplug glasswasher and remove front panel.
- Adjust the Fill adjustment knob on the circuit board. Turn knob clockwise to increase fill time or counterclockwise to decrease fill time.
- Leaving the sliding cover open will end the cycle and drain the tank after 30 seconds and cycle can be re-started to check water level again.

Once water level is correct, continue with Step 5.

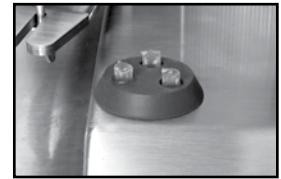

Chemical inlets

FILL mark - top of drain screen handle

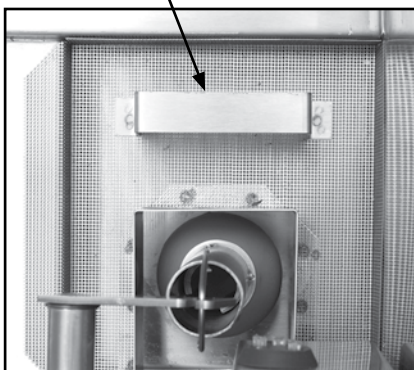

Adjust circuit board knobs as needed

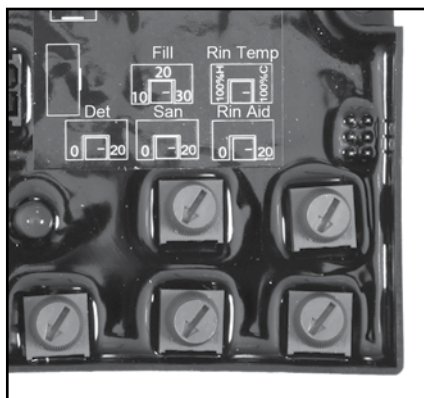

Circuit board slides out for easy access

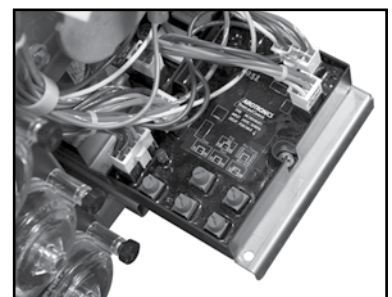

Start-Up Instructions

5. **Rinse Temperature Adjustment:** With the sliding cover closed, initiate a cycle by pressing Cycle Start to check rinse water temperature (Rin Temp knob is set fully open at the factory and may require adjustment at installation location).

Machine will perform wash cycle and proceed to rinse cycle. NOTE: Wash cycle water temperature must register between 120°F (49°C) and 150°F (66°C). Adjust hot water supply source if necessary.

During rinse cycle (recirculating pump must be on to mix and stabilize temperature reading), observe digital temperature read out. The sliding cover can also be opened, interrupting the rinse cycle to insert thermometer into the tank water. NOTE: Minimum rinse temperature is 75°F (24°C) per FDA Ordinance and Code for Food Service Establishments, Section 5-103(e)(2).

If the rinse water temperature is at desired temperature, skip to Step 6.

If the rinse water temperature is not correct, temperature adjustment is required.

- Unplug glasswasher and remove front panel.
- Adjust the Rin Temp knob counterclockwise to increase rinse temperature and clockwise to decrease the rinse temperature. NOTE: The cold water inlet supply minimum temperature may exceed 75°F, resulting in the inability to lower the water temperature further.
- Leaving the sliding cover open will end the cycle and drain the tank after 30 seconds and cycle can be re-started to check rinse temperature again.

Once rinse water temperature is correct, continue with Step 6.

6. **Chemical Concentration Adjustment:** With the sliding cover closed, initiate a cycle by pressing Cycle Start to check chemical settings.

The chemical strengths should be tested with a professional test kit by the chemical supplier. Water samples should be taken during both the wash cycle and the rinse cycle.

Proper concentration levels:

- Detergent - .30% concentration
- Sanitizer - 50 PPM (sodium hypochlorite [bleach])
- Rinse Aid - until proper sheeting is achieved

If chemical adjustment is correct, skip to Step 8.

Unplug glasswasher, remove front panel, and adjust chemicals on the circuit board as required.

Detergent: If the factory setting does not render the proper concentration, turn the Det adjustment knob clockwise to increase or counterclockwise to decrease the dispense time. Repeat chemical testing procedure and adjust again if necessary.

Sanitizer: If the factory setting does not render the proper concentration, turn the San adjustment knob clockwise to increase or counterclockwise to decrease the dispense time. Repeat chemical testing procedure and adjust again if necessary.

Rinse Aid: If the factory setting does not render the proper level of sheeting, turn the Rin Aid adjustment knob clockwise to increase or counterclockwise to decrease the dispense time. Run a test cycle to check wash results and adjust again if necessary.

7. Replace panel and plug in glasswasher.
Repeat Step 6 to recheck chemical settings.
8. Your glasswasher is now ready for operation.

Control Panel - Wash Cycle

Control Panel Operation

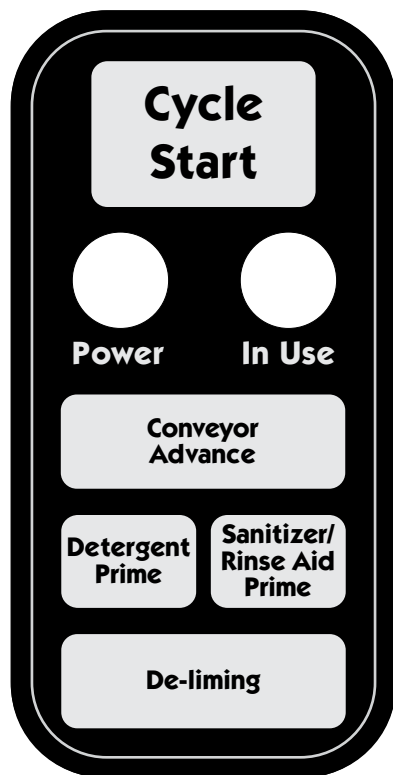

Cycle Start - Push to start wash cycle

Power - Green light* indicates power to unit when illuminated

In Use - Red light* indicates cycle in progress when illuminated

Conveyor Advance - Push to rotate conveyor 1/2 turn to aid in loading/unloading glassware

Detergent Prime - Push and hold to prime detergent

Sanitizer / Rinse Aid Prime - Push and hold to prime sanitizer and rinse aid

De-liming - Push to start de-liming cycle

* Alternating flashing of the red and green light indicates the sliding cover interlock switch has interrupted cycle or a chemical detection switch (optional accessory) has detected a chemical outage.

Wash Cycle Description:

1. Load the conveyor with glassware. To aid in loading the conveyor, rotate the conveyor 1/2 turn by pressing the Conveyor Advance button on the control panel.
 2. Close the sliding cover.
 3. Cycle is initiated by pressing the Cycle Start button on the control panel. Once in cycle, the red In Use light will illuminate.
 4. Wash water fill is initiated and the drain will close when hot water is sensed or 15 seconds into the cycle, whichever is sooner.
 5. Detergent is automatically injected into the tank during fill. The sliding cover can be opened during fill to visually verify detergent is being injected into wash water.*
 6. The wash cycle will automatically start once full. Opening the sliding cover during the wash cycle will pause the cycle, turning off the recirculating pump and conveyor. Closing the sliding cover will continue the cycle.*
 7. At the completion of the wash cycle, the wash water will drain.
 8. The rinse water fill is initiated with the drain open to rinse detergent from the tank. The drain then closes to allow the tank to fill.
 9. Sanitizer and Rinse Aid are automatically injected into the tank during fill. The sliding cover can be opened during fill to visually verify chemicals are being injected into the rinse water.*
 10. The rinse cycle automatically starts once the tank is full. Opening the sliding cover during the rinse cycle will pause the cycle, turning off the recirculating pump and conveyor. Closing the sliding cover will continue the cycle.*
 11. At the completion of the rinse cycle, the rinse water will drain.
 12. The red In Use light will turn off, indicating that the cycle is complete.
 13. Open the sliding cover.
 14. Unload the glassware from the conveyor. Pressing the Conveyor Advance button will rotate the conveyor 1/2 turn to aid in unloading the conveyor.
- * NOTE: If the sliding cover is open for more than 30 seconds, the cycle will terminate and the tank will drain. Press Cycle Start to initiate a new cycle.

Cleaning Instructions

Regular maintenance of your Glastender glasswasher will extend its useful life and lower the service costs. The following parts are removable for daily cleaning:

- | | | |
|----------------------|---------------------|----------------------|
| 1. Drainboard insert | 5. Conveyor | 9. Pump inlet screen |
| 2. Drainboard pan | 6. Spray box | 10. Drain stopper |
| 3. Sliding cover | 7. Spray box gasket | 11. Scrap tray |
| 4. Inner cover | 8. Tank screen | |

The daily cleaning procedures consist of the following steps:

1. Remove drainboard insert, drainboard pan, sliding cover, and inner cover. Wipe down each part as necessary.

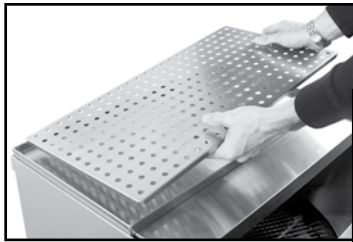

Drainboard insert

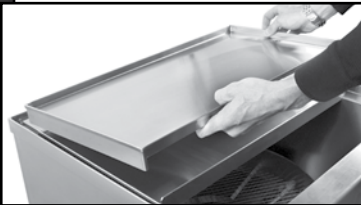

Drainboard pan



Sliding cover



Inner cover



Conveyor

2. Remove the conveyor wheel. Any large debris found inside the machine, like broken glass, lemon seeds, stir sticks, and so on, should be removed.



Spray box
Spray box gasket (located under spray box - not shown)

3. Remove and scrub clean the spray box, spray box gasket, and tank screen. Remove and wipe down the drain stopper. Remove any debris from the lower wash tank. Make sure nothing is clogging the pump inlet screen. The pump inlet screen can be removed for cleaning if necessary.



Tank Screen

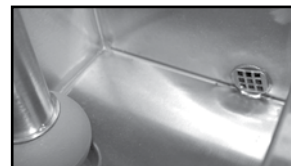

Pump inlet screen



Drain stopper

4. Remove the scrap tray and empty out any debris that may have passed through the tank screen.
5. Use a damp cloth to wipe down the entire wash tank. For more stubborn stains, use a nylon brush or a Scotch-Brite Stainless Steel Cleaner® pad. Never use steel wool to clean stainless steel. Steel wool will cause stainless steel to rust.

Scrap tray



Wash tank



Cleaning Instructions

6. Re-assemble the glasswasher in the opposite order it was disassembled. Pay close attention to the re-assembly of the drainboard insert, drainboard pan, sliding cover, and inner cover. A) Place the inner cover onto and to the back of the tank, aligning the drain hole of the inner cover with the tank drainboard drain hole. B) Place the sliding cover onto the grooves of the inner cover. The sliding cover should be able to be moved back and forth smoothly. C) Place the drainboard pan on top of the inner cover, aligning the drain hole of the drainboard pan with the drain hole of the inner cover. D) Place the drainboard insert into the drainboard pan. E) Verify that the sliding cover can be opened and closed smoothly.

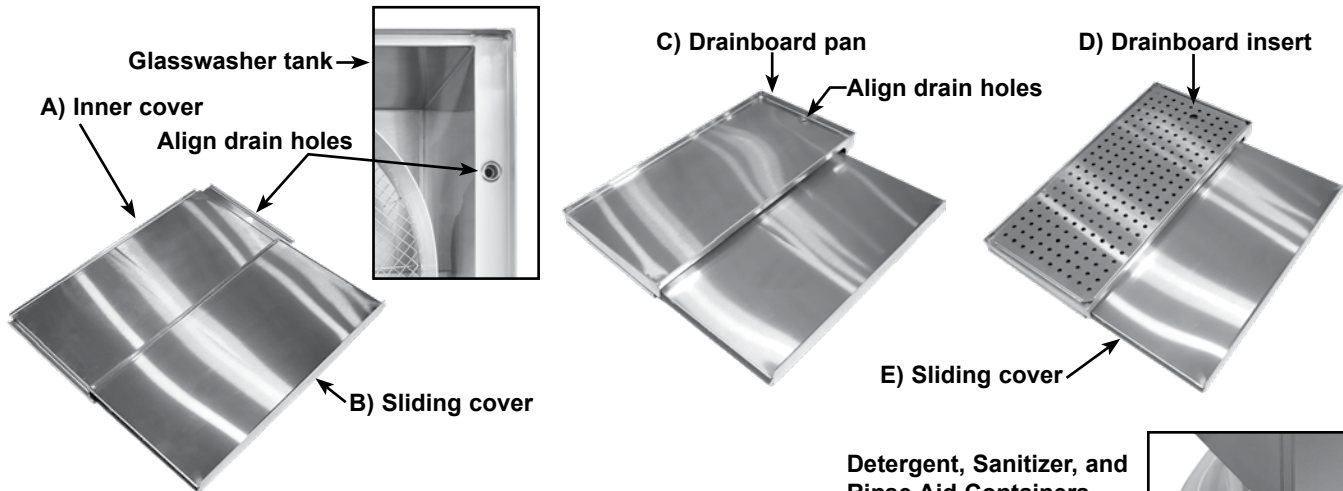

7. Check Detergent, Sanitizer, and Rinse Aid containers. Refill or replace if empty.
8. Visually inspect the Chemical Inlets by opening the sliding cover during the wash and rinse cycle fill. You should notice detergent intermittently dripping into the tank during the wash fill and Sanitizer and Rinse Aid intermittently dripping into the tank during the rinse fill. NOTE: After verifying the chemicals have been dispensed, close the sliding cover to allow the glasswasher to resume cycle. If the sliding cover is left open for more than 30 seconds, the water will be drained and the cycle will terminate. In the event the cycle does terminate, push the Cycle Start button to initiate a new cycle.
9. Your glasswasher is now ready for operation.

Detergent, Sanitizer, and Rinse Aid Containers

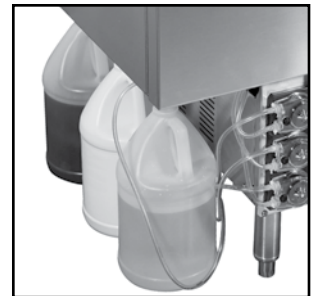

Chemical inlets



De-liming Procedure

When the interior is coated with a white chalky substance, perform the following de-liming procedure. De-liming should be executed after daily cleaning has been completed.

1. With the conveyor empty, press the De-Liming button. The red In Use light will illuminate.
2. The GW24 holds 1.25 gallons of water - measure out the appropriate amount of de-liming solution. WARNING! Most de-liming chemicals are hazardous. Follow chemical manufacturers instructions very carefully!
3. During water fill, open sliding cover and pour de-liming chemicals into tank. Close sliding cover.
4. The de-liming cycle consists of a 5 minute wash and two rinse cycles.
5. The red In Use light will turn off after the de-liming cycle is complete.

Slide-out Chemical Bottle Rack Installation



A slide-out chemical bottle rack accessory is available for easy-access storage of chemical bottles. Specify part number 01001500.

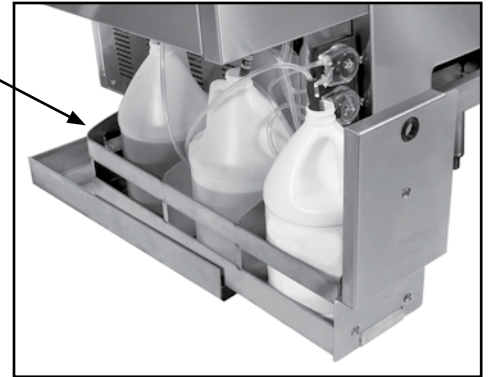

The chemical bottle rack accessory consists of two parts - a stationary bottom tray and a slide-out chemical bottle holder.

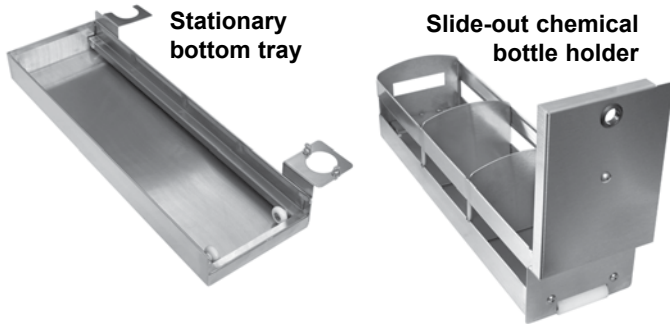

To install the chemical bottle rack onto the GW24:

1. Remove the screw located at the front of the stationary bottom tray and set aside. Pivot the hinge fully to open the securing clasp.

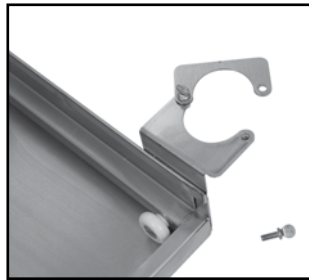

2. Position the back rear semi-circular cutout of the tray around the back left leg of the GW24. Slide the front securing clasp around the front left leg of the GW24.

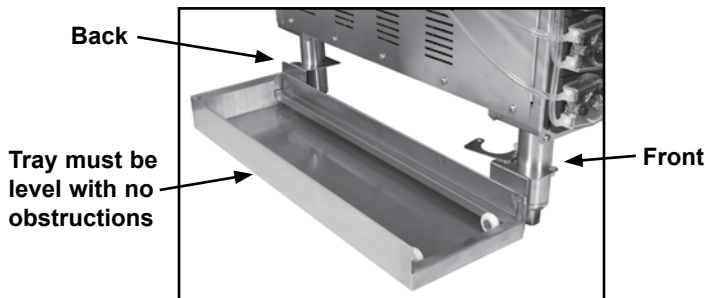

3. Close the securing clasp around the front leg and reinstall the screw.

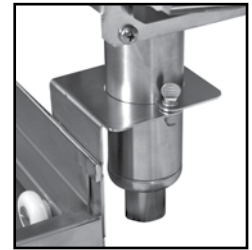
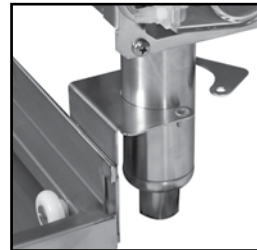

4. Place the slide-out chemical bottle holder into the stationary bottom tray.

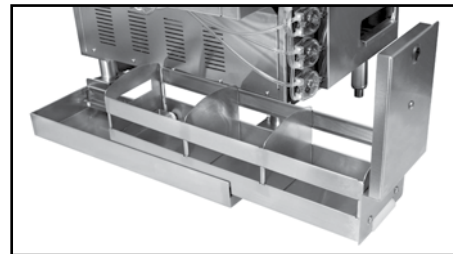

5. The front cover of the chemical tray can be adjusted vertically to fine-tune the fit beneath the GW24 skin. To adjust, loosen the 3 attachment screws on the inside of the front cover. Move the cover up/down. Once the cover is at the desired height, retighten the attachment screws.

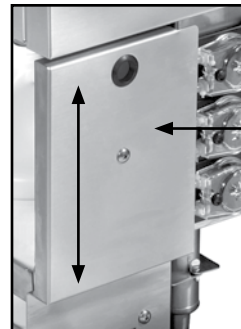

Adjust the front cover up or down

Attachment screws

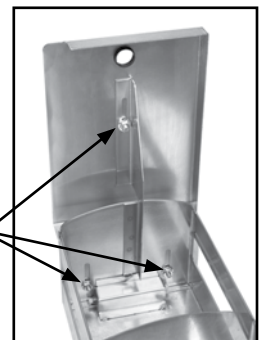

Useful Information About Water, Detergent, & Sanitizer

Water Conditions

Your water supply fits one of the following descriptions.
Greater detergent consumption is required with “hard” water.

<u>DESCRIPTION</u>	<u>GRAINS PER GALLON</u>	<u>PARTS PER MILLION</u>
Soft	Less than 1.0	Less than 17.1
Slightly Hard	1.0 to 3.5	17.1 to 60
Moderately Hard	3.5 to 7.0	60 to 120
Hard	7.0 to 10.5	120 to 180
Very Hard	10.5 and over	180 and over

Detergent Titrating Instructions

An Alkalinity Test Kit, as recommended by your chemical supplier, is required for proper chemical adjustment. Follow kit instructions to test.

Sanitizer Titrating Instructions

After the water has agitated during the rinse cycle, open the sliding cover and dip a Chlorine test strip into the tank for one (1) second. Immediately compare the strip to the scale on the side of the test strip container tube. Adjust sanitizer (bleach) to 50 PPM, and iodine type sanitizer to 12.5 PPM. NOTE: Leaving the sliding cover open more than 30 seconds will end the cycle and drain the tank.

IMPORTANT NOTE: Glasswashers are **NOT** water conditioners. Consult local water conditioning experts to determine your specific water condition.

Important Information About Chemicals

The GW24 glasswasher has chemical pumps that automatically dispense chemicals into the machine. The detergent and sanitizer chemicals are supplied by a chemical vendor. Since the type of chemicals and the condition of water varies by region, the chemical pumps are not pre-set at the factory. *The chemical pumps must be adjusted at start-up to achieve the proper titration levels or the machine may not produce good wash results.* Typically, the chemical vendor is responsible for adjusting the chemical pumps.

Since detergent and sanitizer chemicals play an important role in the performance of a glasswasher, understanding how the chemical pumps work and how to maintain them is very important. Reviewing the following information will help ensure the proper operation of your glasswasher and its chemical pumps:

1. **CAUTION:** Always cycle the machine after using the prime switches to rinse out the wash/rinse tank. Undiluted chemicals will damage stainless steel.
2. The chemical feed lines must be properly placed inside the appropriate chemical container. Damaged chemical lines will spill chemicals on the machine and floor and create poor wash results.
3. Every glasswasher requires chemical pump adjustment and titrating by a chemical vendor. Poor wash results will occur if the chemicals are not in proper concentration (see page 5, Step 6, for proper concentration levels).
4. Glasswasher chemicals are highly caustic and will cause severe burns when they contact human skin. These same caustic chemicals will also corrode stainless steel and destroy machine components. A glasswasher should be checked regularly for chemical leaks. Any leaks should be corrected immediately.
5. All of the chemical tubing on a glasswasher should be inspected regularly and replaced at least once per year. The highly caustic chemicals cause the chemical tubing to get brittle, and since leaking chemicals destroy glasswasher components, it is good preventative maintenance to replace chemical tubing often. The various tubing includes the lower tubing assembly or main chemical feed line, the pump squeeze tube (especially susceptible to damage), and the upper tubing assembly from the pump to the glasswasher tank.
6. Chemical vendors that deliver chemicals to your establishment are typically responsible for adjusting the chemical levels in your glasswasher. They are also helpful for assisting you with chemical tubing inspection and replacement. Nothing removes your responsibility for proper maintenance, but the chemical vendor will help.

Tips for Trouble-Free Operation

1. **NEVER, NEVER** wash ash trays in the glasswasher. Since ashes are smaller than the opening in the Pump Inlet Screens, ashes can adhere to glasses. Also, with ashes recirculating in the wash water, the cleaning effectiveness of the detergent is greatly reduced. The final result of washing ash trays is dirty glasses.
2. For best results, run glasswasher full of glassware. This keeps the water and detergent consumption to a minimum and helps prevent glassware from tipping over.
3. Water spotting can occur when glassware is placed on a flat surface after washing, thus preventing air to assist the drying process. Make sure the proper shelf liner or drying surface is used.
4. Clearance below the top cover of the glasswasher allows for a maximum glass height of ten (10) inches. Keep this in mind when ordering beer pitchers and wine carafes.
5. Glasses which have been frequently washed by hand may have deposits of invisible "film". Although initially appearing clean, these glasses may show unsightly signs of "dirt" after passing through the glasswasher. This unsightly condition will exist until the film is removed with frequent passes through the glasswasher, or it may be necessary to use a de-liming agent to clean glassware.
6. Do not place wet glasses into glass chillers or frosters. Allow glasses to dry and sanitizer odors to dissipate first.
7. Changing detergents may require readjustment of the Detergent Pump to maintain .30% detergent concentration. A greater volume of low strength detergent is required to maintain the proper level.
8. Only Glastender, Inc. replacement parts should be used. Components from other suppliers may result in machine malfunctions.

Please consult your Glastender, Inc. service agent if service or technical assistance is required. The factory is also available to answer any operational questions.

Trouble Shooting Guide

Trouble or Situation	Cause	Remedy
A. Unit does not run	<ol style="list-style-type: none"> 1. Sliding cover open 2. Out of chemicals 3. No power (Power light "off") 4. Defective switch panel 5. Wire connections poor, loose, or broken 	<ol style="list-style-type: none"> 1. Close sliding cover 2. Replace and prime empty chemicals 3. Check power source 4. Replace switch panel 5. Re-crimp and/or replace wire connection
B. Unit experiences a delay (up to 15 seconds) before beginning a cycle	<ol style="list-style-type: none"> 1. Incoming water does not reach minimum operating temperature 	<ol style="list-style-type: none"> 1. Check temperature of water source
C. Conveyor runs but holding tank not filling	<ol style="list-style-type: none"> 1. Water "off" 2. Bad water valve 	<ol style="list-style-type: none"> 1. Turn water "on" 2. Test valve, replace if necessary
D. Conveyor moves intermittently	<ol style="list-style-type: none"> 1. Glassware or debris blocking rotation of conveyor 2. Worn drive coupling 	<ol style="list-style-type: none"> 1. Clear obstruction 2. Replace drive coupling
E. Water recirculating, conveyor not moving	<ol style="list-style-type: none"> 1. Obstruction in tank area 2. Conveyor not engaged with conveyor drive shaft 3. Worn drive coupling 4. Defective drive motor 	<ol style="list-style-type: none"> 1. Remove obstruction 2. Rotate conveyor until it engages 3. Replace drive coupling 4. Replace drive motor
F. Water not recirculating	<ol style="list-style-type: none"> 1. Completely plugged pump inlet screen 2. Defective recirculating pump 	<ol style="list-style-type: none"> 1. Clean pump inlet screen 2. Replace recirculating pump
G. Water leaking from recirculating pump housing - water on floor	<ol style="list-style-type: none"> 1. Defective pump seal 2. Pump housing cracked 	<ol style="list-style-type: none"> 1. Replace pump 2. Replace pump
H. Glasses slimy or soapy at end of cycle	<ol style="list-style-type: none"> 1. Sanitizer feed line in detergent container 2. Improper Rinse Aid setting 	<ol style="list-style-type: none"> 1. Clean line and place in proper container 2. Adjust chemical setting
I. Recirculating water pressure low	<ol style="list-style-type: none"> 1. Spray box not latched properly 2. Partially plugged pump inlet screen 3. Missing or worn spray box gasket 	<ol style="list-style-type: none"> 1. Latch spray box properly 2. Clean pump inlet screen Refer to page 8 cleaning instructions 3. Replace gasket
J. Detergent, sanitizer, and/or rinse aid not feeding properly	<ol style="list-style-type: none"> 1. Chemical container is empty 2. Feed lines will not fill 	<ol style="list-style-type: none"> 1. Refill or replace container(s) 2. Replace defective parts. Notes: The detergent, sanitizer, or rinse aid product advances in the line on each stroke of the pump. The product should hold position between strokes. If the product falls back toward the supply container, one or more of the following conditions may exist: <ol style="list-style-type: none"> a. Debris in pump b. Split feed line c. Bad pump tube Replace parts as necessary
K. Poor washing results	<ol style="list-style-type: none"> 1. Clogged spray nozzles and dirty holding tank 2. Detergent container empty 3. Poor water conditions 4. Chemicals not adjusted properly 5. No hot water 	<ol style="list-style-type: none"> 1. Clean unit -see page 8 cleaning instructions 2. Fill container 3. Have filter or softener installed 4. Call chemical technician 5. Check temperature of water source