

Operation Manual

Glastender®

A Family Company Manufacturing
In The USA Since 1969

SELF-CONTAINED FRONT SERVICED COOLERS & FROSTERS

This manual is specific to the following front-serviced coolers:

- C1FB, C2FB, C1FL, CP1FB, CP1FL, C1FU, CS1FB, F1FB, F1FL
- KC - beginning with SN 290187703 and manufactured April 15, 2019 and after



C1FB60 with compressor right, stainless doors/drawers, and stainless top

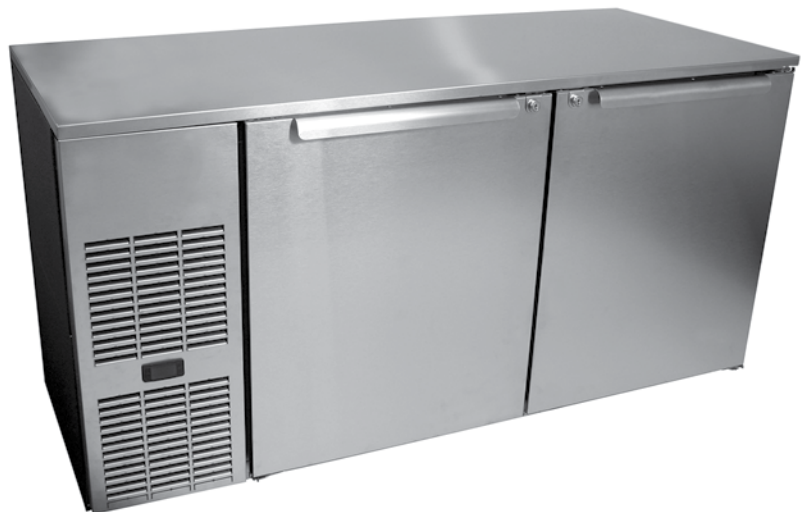

C1FL60 with compressor left, stainless doors and top, and stainless pull tab handle

Glastender, Inc. · 5400 North Michigan Road · Saginaw, MI · 48604-9780
800.748.0423 · 989.752.4275 · Fax 989.752.4444 · <https://glastender.com>



Index

COOLER SERIAL NUMBER INFORMATION	COVER
DIGITAL CONTROLLER OPERATION	2 - 3
INSTALLATION	
Introduction	4
Important Outdoor Use Considerations	4
Utility Requirements and Connections	4
Uncrating and Start-Up Instructions	4
Sealing Vertical Door Cooler to Floor Instructions	5
Cooler Installation Checklist	5
Beer Tower Installation	6
Cleaning Instructions	6
SPECIFICATIONS	
CS1FB Anti-Tip Bracket Installation	7
Wiring Diagrams	8 - 10

**For replacement part information, visit:
<https://support.glastender.com/>**

**WARNING: Components shall be replaced with like components only.
Service shall be done by factory authorized service personnel only,
so as to minimize the risk of possible ignition due to incorrect parts
or improper service.**

Terms and Conditions

<https://www.glastender.com/support/documents/policies/terms-and-conditions>

Warranty

IMPORTANT !! Attention Service Companies IMPORTANT !!

Please review the important warranty information found here:

<https://www.glastender.com/support/documents/warranty/warranty-statement-form>

If you believe a service call should be covered by the factory, please call 800-748-0423
for authorization 8AM - 5PM EST, Monday through Friday.

Digital Controller Operation

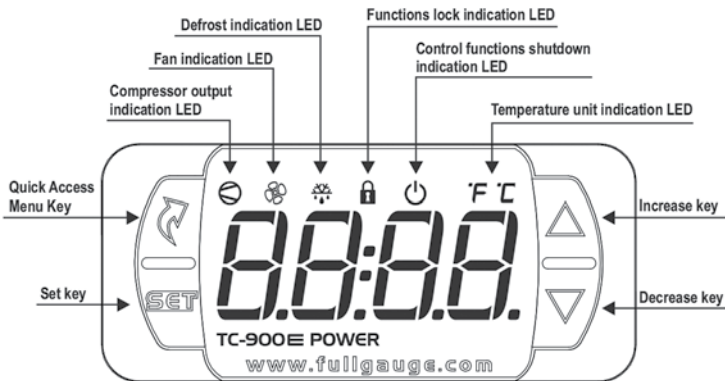

Setting Desired Temperature

The operating temperature is preset at the factory according to the table below and can be adjusted up or down within the limits shown. Press the Quick Access Menu Key 6 times until SP appears on the display. Press the Set key. Use the increase or decrease keys to modify the value. Press the Set key to confirm.

For units manufactured prior to June 2021, turning digital controller ON/OFF: All cooler models can be turned ON/OFF by pressing and holding the Quick Access menu key for 5 seconds. When the digital controller is off, the message OFF is displayed alternating with the temperature.



	Factory Settings		Range of Adjustment	
	Set Point	Operating Range†	Minimum Set Point	Maximum Set Point
Standard Cooler Setting	34° F	34° F to 39° F	33° F	65° F
White Wine	50° F	50° F to 55° F	33° F	65° F
Red Wine	60° F	60° F to 65° F	33° F	65° F
Froster Setting	12° F	12° F to 20° F	12° F	35° F

† Adjusting the factory set point will also adjust the operating range by the same amount

Digital Controller Operation

Automatic Defrost

Each time the door is opened, moisture from the outside air enters the cabinet. Consequently, frost builds up on the evaporator coil over time. To eliminate this buildup and keep the unit running efficiently, Glastender coolers and frosters are programmed to automatically defrost 4 or 3 times each day, respectively. Under typical operating conditions, the automatic defrost process will not interfere with the ability of the F1F frosters to hold specialty cocktail ice.

F1F frosters have a manually-activated, 6-hour defrost

Over time, which varies depending on the level of humidity in the air, the F1F frosters will require a manually-activated, 6-hour defrost cycle to completely free the evaporator drain pan of frost buildup. Activate this defrost cycle by pressing the round button below the digital controller. The controller display will alternate between ECO and ON. An in-progress, 6-hour defrost cycle can be canceled at any time by pressing the round button.



Activate the 6-hour defrost cycle at the close of business, at least once per week. The froster will automatically resume normal operation six hours later. Please note, specialty cocktail ice cannot be held during this 6-hour defrost cycle.

Holding specialty cocktail ice in an F1F froster

The F1F family of frosters will hold specialty cocktail ice by following these operational guidelines: Set the digital controller to a temperature set point of 12° F.

Keep the ice in sealed plastic bags or sealed containers.

Once per week, remove all specialty cocktail ice and manually activate the 6-hour defrost cycle by pressing the round button below the digital controller.

If specialty ice melting is observed while following the above guidelines, then it may be necessary to manually activate the 6-hour defrost cycle more than once per week.

Digital Controller Trouble Shooting Error Codes

If the digital controller display shows an Err 1 or Err 3 error code, this is likely the result of disconnected digital controller wires. These wires are commonly disconnected for service and maintenance. Please verify controller wires are connected before calling for service, because service calls to reconnect the controller are not covered by the factory warranty.

Self Contained Coolers Two Zone Models

If the second character of the model number is a “2”, then two separate refrigeration zones are programmed at the factory. EXAMPLE C2FB60.

The door or zone closest to the condenser cover must always be the colder compartment. If the condenser cover and controller are on the left end, then the left door(s) or zone will be the cold side. The right compartment must be set for a minimum of 8°F warmer. The thermostat on the left will control the refrigeration zone on the left. The thermostat on the right will control the zone on the right.

CODE	POSSIBLE CAUSES	RECOMMENDED ACTION
Err 1	Temperature sensing probe wires disconnected from digital controller	Reconnect wires, see wiring diagram provided in operation manual
Err 3	Defective temperature sensing probe	Call for service
Athi	Dirty condenser coil	Clean condenser coil
	Refrigeration system needs service	Call for service
AELO	Refrigeration system needs service	Call for service
AC1	Dirty condenser coil	Clean condenser coil
	Refrigeration system needs service	Call for service
AC2	Dirty condenser coil	Clean condenser coil
	Refrigeration system needs service	Call for service

Installation

INTRODUCTION

This manual describes the operational features of the self-contained coolers listed on the front of this manual. Please review this information before attempting installation and operation.

Long term, trouble-free service will follow if good housekeeping and maintenance procedures are followed. Thank you for selecting Glastender, Inc. products.

IMPORTANT OUTDOOR USE CONSIDERATIONS

Our refrigerated products are not listed to UL standards for outdoor use. We recommend outdoor installations have a roof over the area where our products are in use to protect from direct sun, rain, and snow load.

Our refrigeration models are tested to 100°F ambient to ensure they cool adequately. At 100°F, models listed for open food maintain refrigerated temperature of 40°F or below with less than 70% compressor run time. Mug froster and freezer models will cool, but compressor run time will be high.

For seasonal locations closed during the winter, covering with a tarp is acceptable to protect the units from blowing snow. Tarps or coverings must be vented to prevent condensation which could result in corrosion occurring on the unit. Locations subject to ambient temperatures below 50°F require coolers and other refrigeration models to be unplugged, or circuits turned off during these temperatures as the compressor is not designed to operate below these temperatures.

UTILITY REQUIREMENTS AND CONNECTIONS

- **Electrical:** 120 Volt AC, 1 Phase, 60 Hz. A separate 15 Amp circuit is recommended. A 6-foot grounded cord and plug is included with self-contained models.
- **Plumbing:** Automatic condensate evaporator is included. No drain connection required.

UNCRATING AND START-UP INSTRUCTIONS

Caution - This Refrigerator contains Flammable R290 Refrigerant. When moving and handling this equipment take care not to damage the refrigerant tubing or components.

All models are shipped in one carton. These steps should be followed:

1. If legs or casters are included:
 - Legs - install threaded legs into receiving holes and turn until tight to the flat surface.
 - Casters - attach to base with provided bolts.
2. Unwrap power cord from base if included.
3. Position unit and level and/or seal as required (see page 4 and 5).
4. All units intended for draft beer must be plumbed to an external drain. On self-contained models with draft beer and a factory installed finished top, the beer tower drain pan is plumbed through the cabinet and stubs out in the 3" space below the compressor compartment. Connection to an external drain must be made from that point.
5. Place shelves in desired location.
6. Plug into 115 volt AC outlet.
7. Load with bottles or cans and allow time for products to cool.
8. Your Glastender equipment is now ready for use.

Installation

SEALING VERTICAL DOOR COOLER TO FLOOR

To establish proper sanitation operation and to comply with NSF & health codes, the cooler base must be sealed to the surface to which it is mounted using an NSF listed sealant. Place a bead of sealant along outer edges of the base and remove any excessive amount. Make sure there are no gaps in the sealant as the intent is to prevent liquid spillage from adjacent surfaces from passing under inaccessible portions of the equipment. This sealing procedure does not apply to models that include legs or casters.

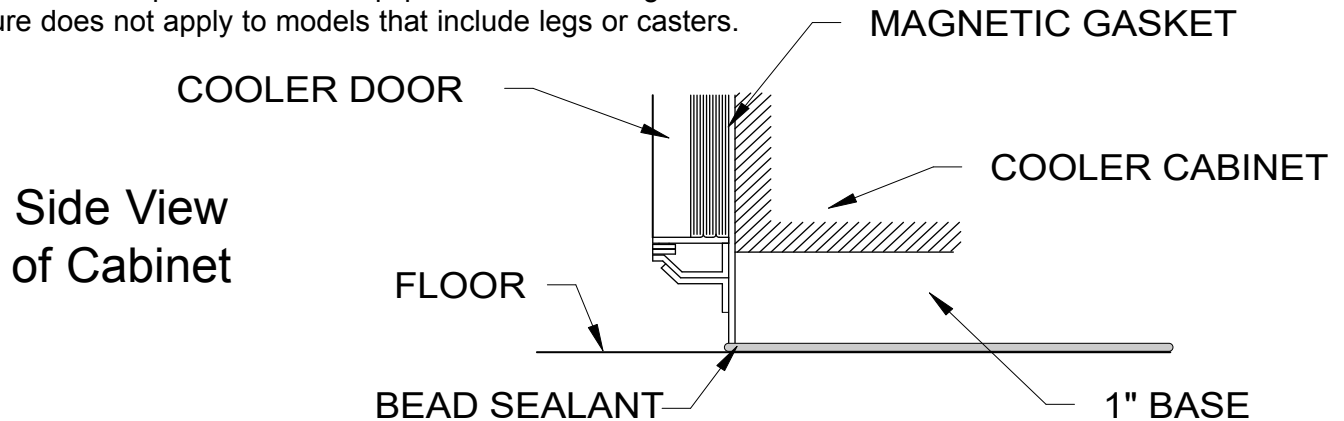

ATTENTION INSTALLER: WARNING!!

Failure to level this cooler WILL VOID THE FACTORY WARRANTY. Doors will not close properly causing damage to hinges, handles, and/or gaskets which will adversely affect the refrigeration systems.

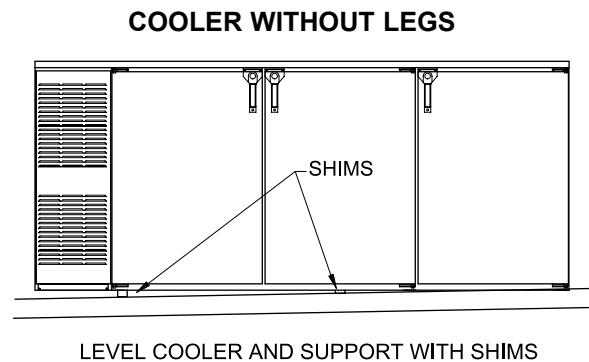
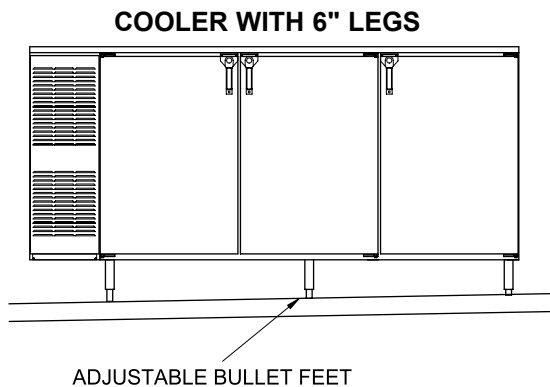

COOLER INSTALLATION CHECKLIST

- Is the unit evenly and solidly supported, either upon legs, or flat on the base; check for high spots?
- If the unit was designed for legs, are they attached?
- Is the unit level at the base, from end to end?
- Do the doors open and close freely, without touching any other part of the unit in travel?
- Are all open holes to the outside of the cabinet plugged or insulated?
- Are there obstructions of any kind to air flow into or out of the condensing unit?
- Is product tubing or are other lines installed in such a manner to not allow shelf access?

Installation

SPECIAL INSTRUCTIONS FOR BEER TOWER INSTALLATION

Before you begin:

1. Disassemble the tower into three parts, stiffener, skin, and top plate, by unscrewing the top two screws.
2. Mount the column stiffener with the provided four 1/4"-20x1-1/2" bolts.
3. Install insulation provided into the bottom of the column stiffener.
4. Place the column skin over the stiffener. Run the beer lines through the hole at the same time.
5. Install insulation provided into the top of the tower assembly.
6. Mount the column top plate to the column stiffener with the two #10-32x1/2" phillips flat head s/s machine screws provided.
7. Apply a bead of silicone sealant around the perimeter of the column. Use your finger to smooth out the bead.
8. Wash tapping device and faucet with detergent and water. Flush beer tapping device and faucet lines.

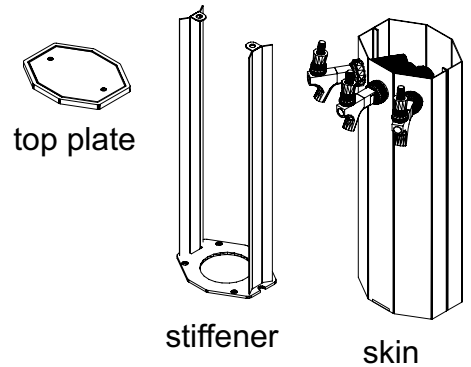

Cleaning

CLEANING INSTRUCTIONS

Cleaning is essential to sustaining the integrity of your equipment and preventing corrosion.

ESTIMATED CLEANING TIME: 5 to 10 minutes per unit daily, 45 minutes quarterly

FREQUENCY: Daily cleaning of exterior & door gaskets. Monthly cleaning of condenser filter. Quarterly cleaning of interior, including shelves.

PROCEDURE:

1. A non-chlorine based cleaner or mild detergent and warm water applied with a soft cloth or sponge to all contact surfaces.
2. Immediately rinse off cleaning agent(s), using clean warm water, clean soft cloth or sponge.
3. Dry with a soft clean cloth, removing standing water as soon as possible.
4. Condenser filter - remove compressor cover panel. Thermostat control probe wire will become disconnected and cause operation failure not covered by factory warranty (see page 2). Be careful while removing.

NOTES:

1. Never use hydrochloric acid, wire brushes, steel wool, scrapers, or chlorine based cleaners on stainless steel surfaces, since they will break down the passivity layer and allow corrosion to occur.
2. On stainless steel surfaces, you may use a soft bristle brush or Scotch-Brite® pad for more stubborn stains. Always scrub with the direction of the grain. Follow with a thorough cleaning as described above.
3. Deposits from food preparation must be properly removed. Even hard water deposits will rust stainless steel, if not removed.
4. Repeated cleaning may dry up black-vinyl-clad steel (exterior) surfaces of the cooler. Armor All® or similar product can bring back the shine. Apply the product to a cloth and then rub into the surface, rather than spraying it directly onto the black-vinyl-clad surface.
5. The cooler door gaskets are most often overlooked when cleaning. Failure to clean them regularly will lead to premature failure, since alcohol and moisture build-up breaks down the gasket material.



Thermostat control probe wire will become disconnected when compressor panel is removed

CS1FB Anti-Tip Bracket Installation

WARNING: The included anti-tip bracket **MUST** be installed when CS1FB is in use.

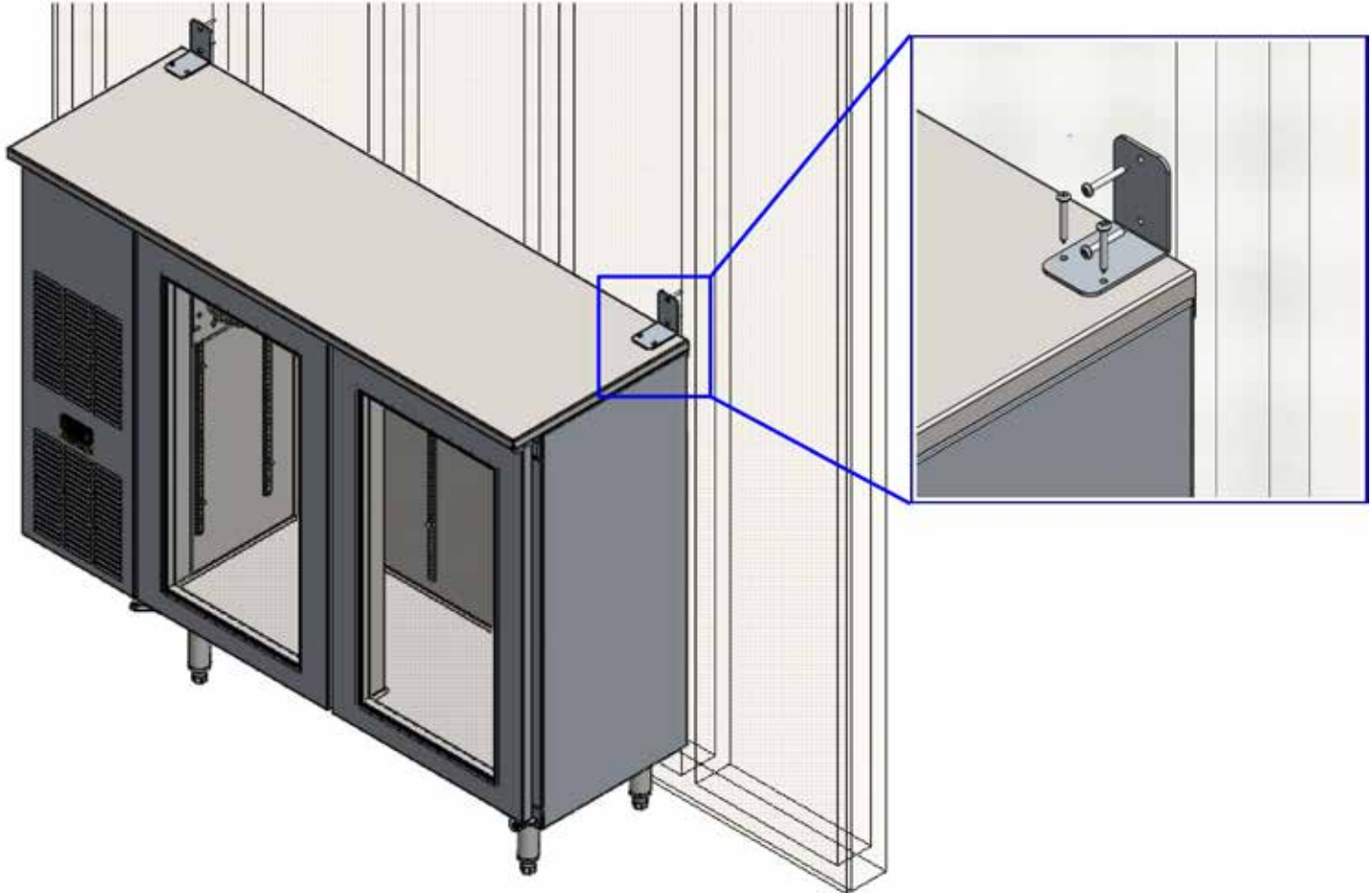

INSTALLATION INSTRUCTIONS WITH CASTERS

1. Install casters on cooler.
 2. Slide cooler into position. Locate wall studs and mark bracket holes.
 3. Slide cooler out and secure the bracket with 2 wood screws.
 4. Set the cooler in its final position.
- * To utilize the casters, do not secure the brackets to the top of the cooler.

INSTALLATION INSTRUCTIONS WITH LEGS

1. Install the cooler legs.
2. Set the cooler into position. Locate wall studs and mark bracket holes.
3. Mount each bracket to a wall stud with 2 wood screws.
4. Set the cooler in its final position.
5. Secure brackets to the top with provided stainless sheet metal screws.

Wiring Diagram C1F

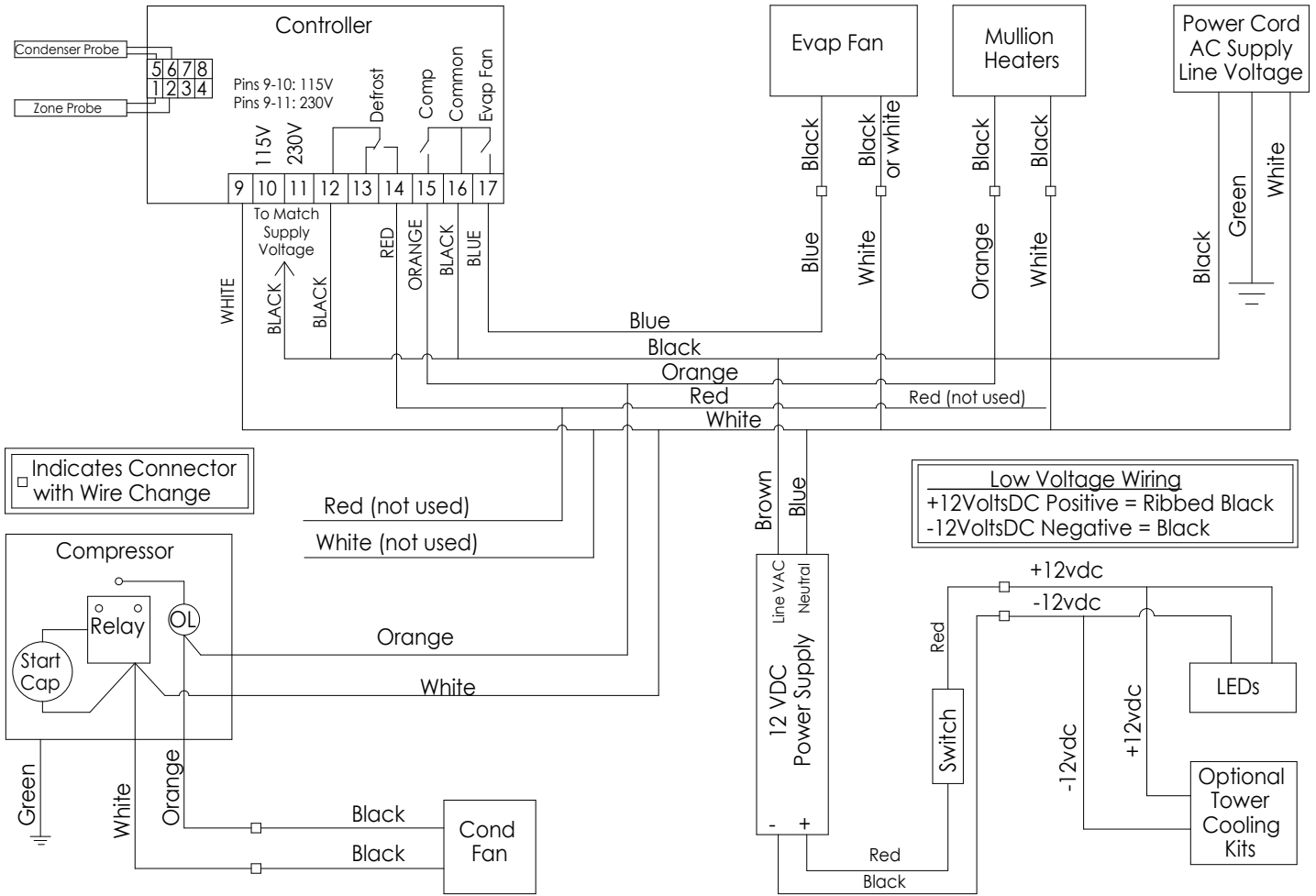

Wiring Diagram F1F

