

# Glastender®

GD24HT GLASSWASHER



# Features

Crystal-clean glassware is the first priority in delivering an exceptional drink experience. The GD24HT uses hot water cycles to efficiently and effectively remove residues and sanitize glassware without chlorinated solvents.



## Simple, Flexible Operation

Select one of three timed cycles on the digital LED control panel, then push Start. The GD24HT features a recirculating wash design with fresh water rinse, delime cycle, and high-temp sanitation system.

## Practical, Energy Saving Design

The GD24HT collects hot water vapor generated during wash and rinse cycles to preheat incoming water. This design allows the unit to operate from a single cold water supply, permitting installation at the bar, saving energy, and reducing steam for an improved operator experience.

## Soft Start for Glassware Protection

Reducing the initial pressure of the wash pump to protect glassware from chipping and breaking, as well as lower the risk of injury and costs associated with replacing glassware.

## Additional Highlights

- Accepts standard 20" x 20" glass racks
- 6" legs provide clearance for cleaning
- Service diagnostics provided through digital LED display
- Automatic pumped drain for floor & wall drain installations
- Built-in chemical pumps and priming switches
- Double wall cabinet quiets operation, reduces heat loss

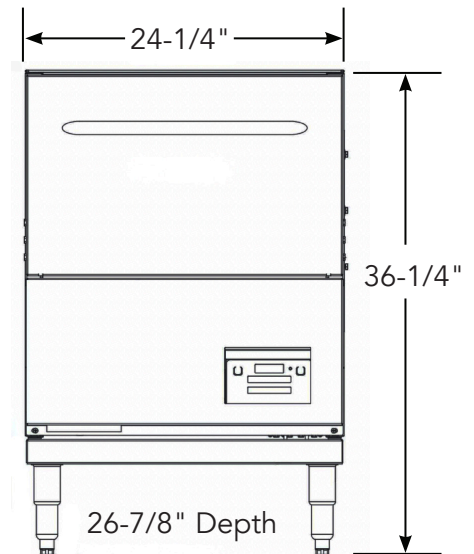

Scan this code to view spec sheets, installation manuals, and pricing.

