

Glastender®

ELEVATION



The Rise of a New Underbar

We began manufacturing elevated underbar equipment for iconic luxury brands in 2018. Since then, it's been revolutionary in its profoundly different experience for customers and staff.

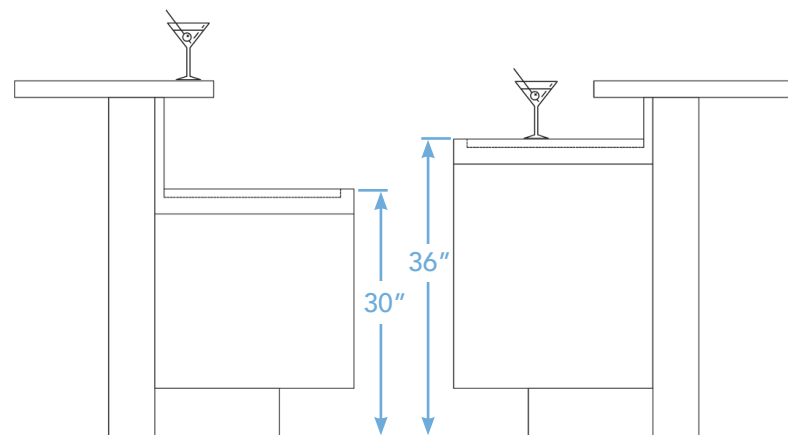

This industry-advancing line features a 36" high work surface, six inches higher than traditional underbar equipment, while the bar top remains at a comfortable height of 42".

One of the more impactful features of Elevation is how the higher work height improves the customer's ability to see what is happening behind the bar. The artistry of cocktail crafting goes largely unseen by the customer in a traditional layout.



By raising the worksurface height, customers can now see the steps a bartender takes to craft their cocktails.

Similar to how open kitchens brought the excitement of the kitchen to the customer, those sitting at an Elevation bar will experience the attention to detail that goes into their cocktail.



TRADITIONAL



ELEVATION

Elevation offers more than a different look for bartenders, often improving ergonomics by reducing the amount of bending and awkward motions needed throughout their shift.

The higher worksurface provides a comfortable area for bartenders to prepare cocktails, eliminating the need for bar-top drink rails.



Fundamental Approach to Design



Cocktail Life Cycle

With the enhanced experience offered to customers through the raised worksurface, cocktail assembly steps are now centered on the workstation rather than the ice bin.

DRAINBOARDS

Extensive glassware storage with sanitary perforated insert to speed drying time.

Choose a glass rack, half-cabinet, or full cabinet base for flexible storage and added functionality.

ICE BINS

Easy to clean, and features thermal barrier liner, direct cold plate contact, and foamed-in-place insulation to maximize ice usage.

LIQUOR STORAGE

Wall-mount Liquor displays feature retaining rails to prevent tipping and an extra deep rear step for specialty liquor bottle storage.

Speed rails are sound-deadening and attach to equipment without further distancing a bartender from patrons.

MIXOLOGY UNITS

Create your ideal mixology unit with combinations of a backsplash faucet, push-down rinser faucet, cutting board, and a seamless welded dipper well with faucet for mixology tools.

SODA DISPENSING*

Soda guns and manifolds mount to ice bins for efficient bartender workflow.

CRAFT ICE FREEZER*

Conveniently stores specialty ice for up to two weeks while preserving pristine clarity, taste, and shape.

GARNISH SOLUTIONS

Ice-chilled, non-chilled, and refrigerated storage options are available to suit your garnish style.

COCKTAIL PREP COOLER

Features a refrigerated mixology well, garnish station, drink rail surface with removable cutting board, and a high-capacity refrigerated drawer with slide-out racks.

WET + DRY WASTE

Attractive, smart solutions for wet and dry waste disposal to maintain a top-notch appearance.

FUSION SINK

Patented design combines a hand sink and wet waste sink into one to optimize space and behind the bar.

GLASSWASHERS*

Our high-temp glasswasher is designed to align seamlessly in an Elevation lineup.

POS STATIONS*

Sized to fit a cash drawer and monitor, freeing essential countertop space while providing secure storage.

*Available, not shown.

Core Stations

Select an ice-chilled or refrigerated core station and then begin designing other elements around the workstation.



Unique Features

The additional equipment height also allows for improved use of space behind the bar, adding functionality, like full-extension pull-out liquor drawers not possible with traditional underbar equipment.

Improved storage helps promote an efficient workflow for staff and streamlined customer service.



Pull-out drawers add bottle storage underneath liquor display units.



Pull-out racks for quick access to clean glassware.



Built-in drawers offer storage for mixology tools.



Cabinet bases offer storage for supplies and equipment.

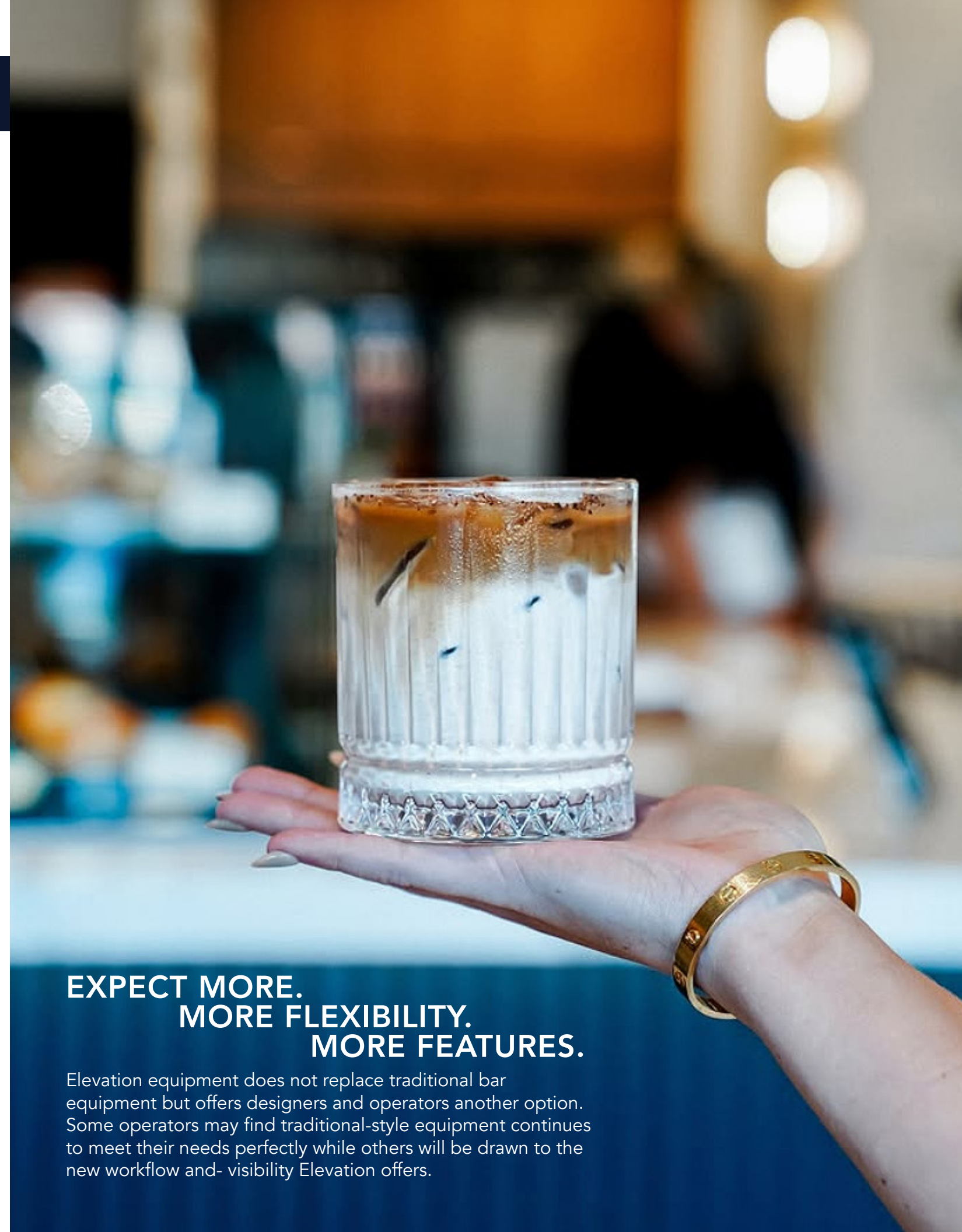

**EXPECT MORE.
MORE FLEXIBILITY.
MORE FEATURES.**

Elevation equipment does not replace traditional bar equipment but offers designers and operators another option. Some operators may find traditional-style equipment continues to meet their needs perfectly while others will be drawn to the new workflow and- visibility Elevation offers.

Glastender®

Expect More. More Flexibility. More Features.

Want to see your bar design come to life?

Visit our interactive equipment configurator & layout tool at <https://designer.glastender.com>

GTdesigner by Glastender

